

# Tunnel thruster version

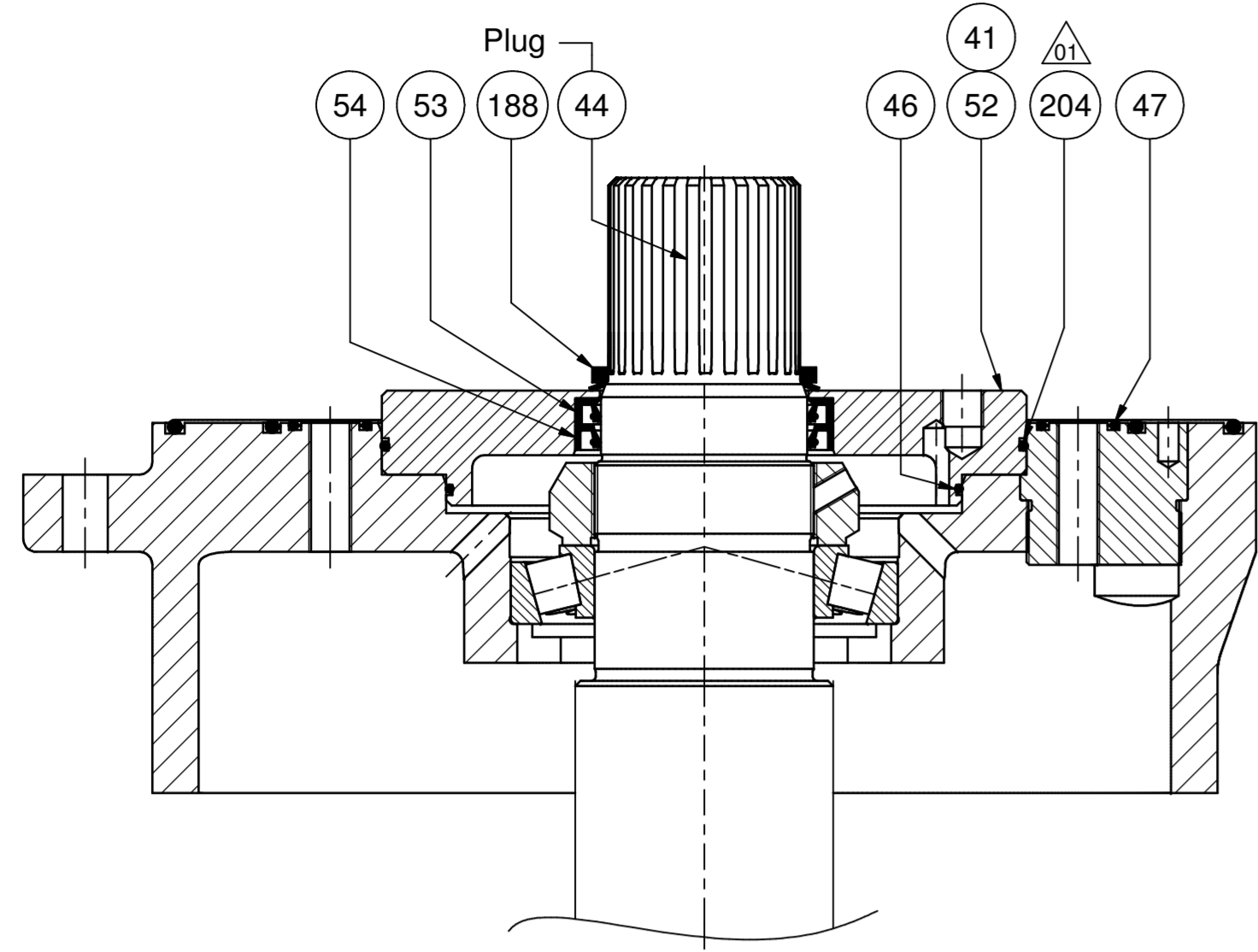

Bolt 84  
42  
Slots must point in direction of oil holes in the top flange

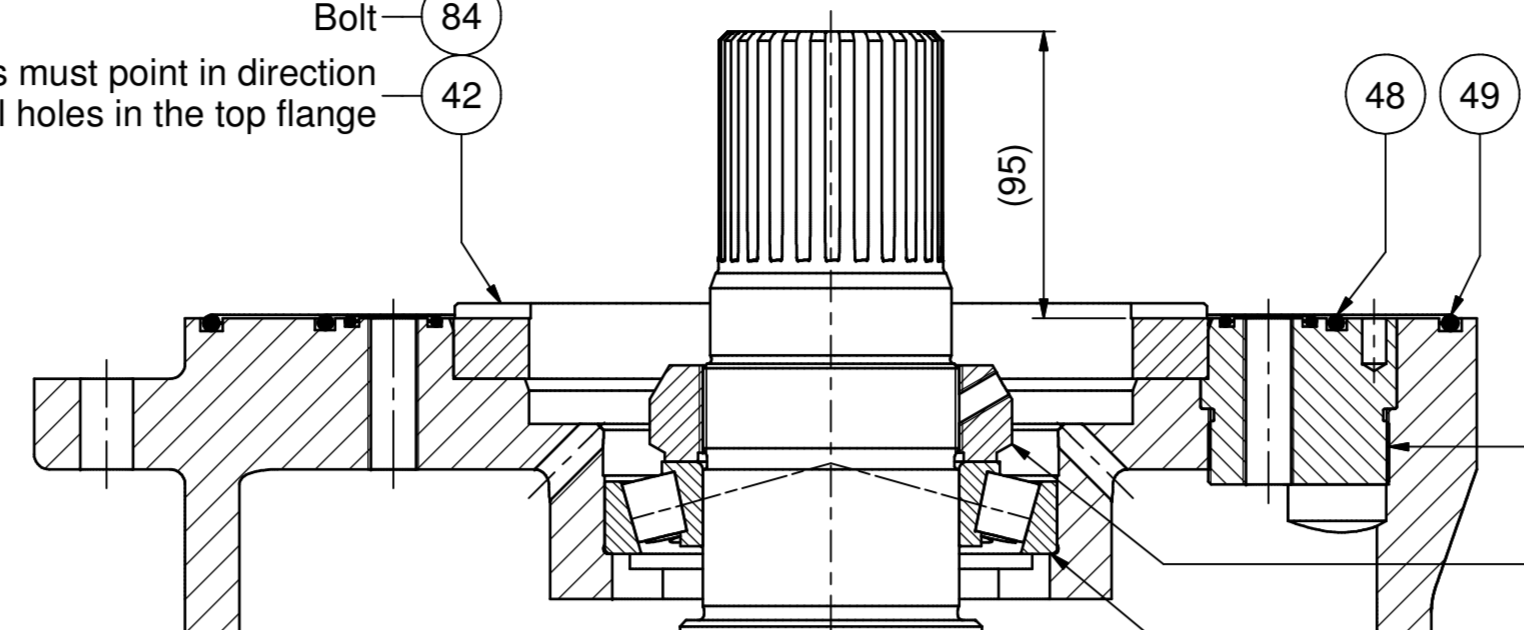

- 02 1200rpm CW (Standard)
- 177 1200rpm CCW
- 94 1500rpm
- 92 1800rpm

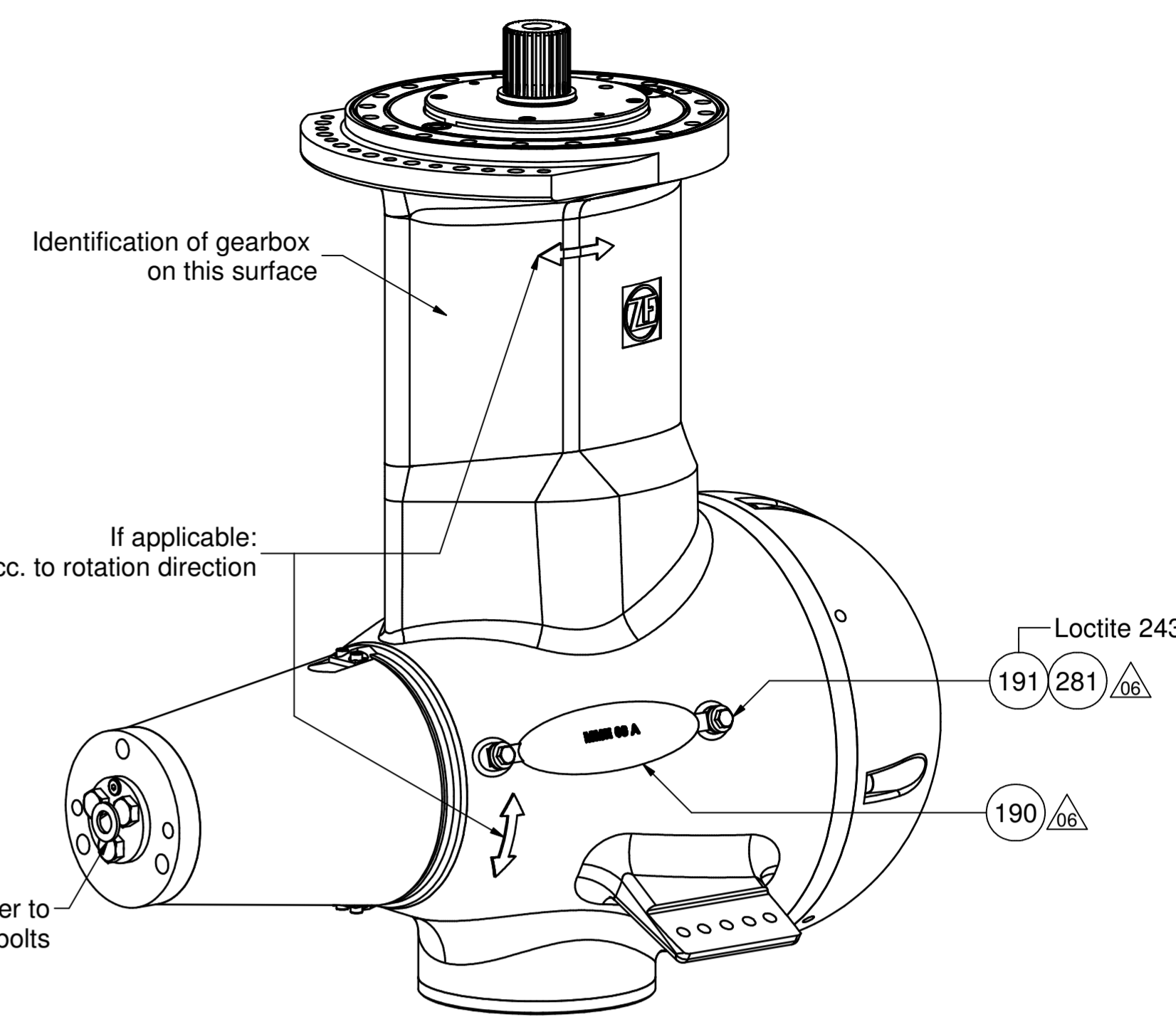

## View 1

(Bolts for mounting Pos. 07 and Pos. 15)

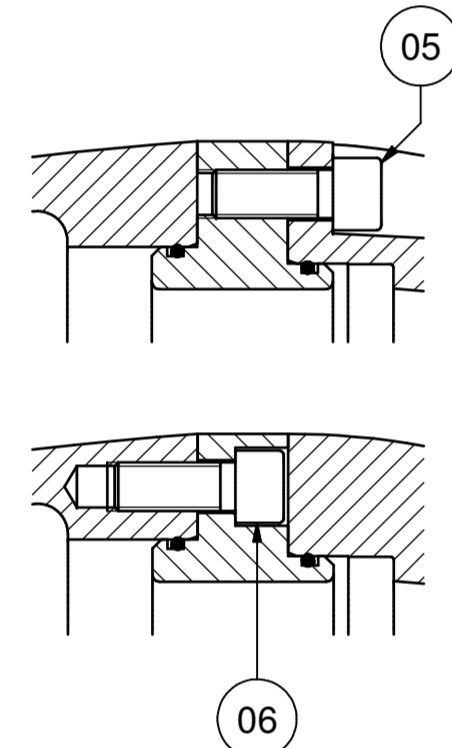

Drill center points in propeller shaft before mounting set screws with Loctite 243

